

1T-1HT/3T-1FT/3T-1ST/6T-1FT/6T-1ST/7T-1HI-VIZ /9T-1FT SITE DUMPERS

STATIC DIMENSIONS AND CAPACITIES

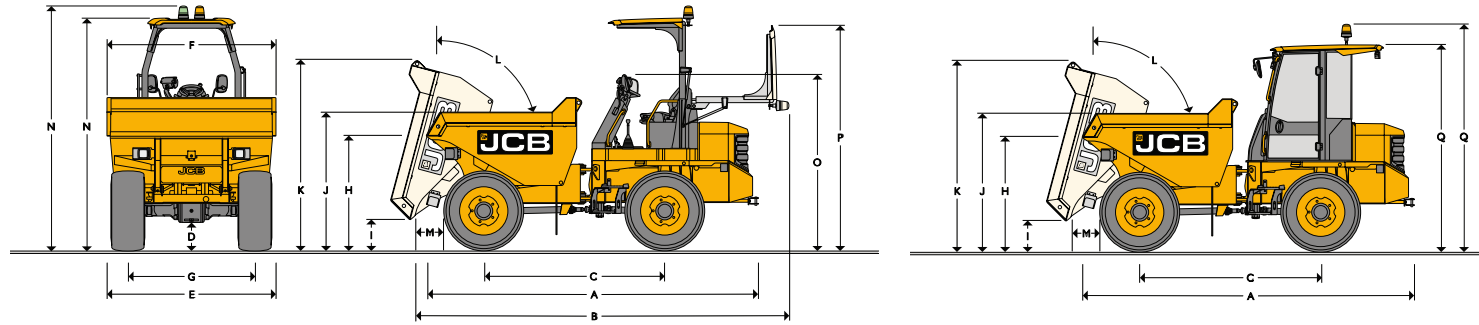

STATIC DIMENSIONS AND CAPACITIES

		1T-1 HT	3T-1 FT	3T-1 ST	6T-1 FT	6T-1 ST	7T-1 Hi-Viz FT	9T-1 FT
A	Overall length	mm	3095	3758	3926	4792	5047	4912
B	Overall length (ROPS or FOPS folded)	mm	3403	4192	4360	5023	-	5141
C	Wheelbase	mm	1500	1950	1950	2480	2940	2680
D	Minimum ground clearance	mm	263	206	206	312	322	359
E	Total width (normal/thin tyres)	mm	1106/980	1650	1650	2255	2395	2380
F	Skip width	mm	980	1650	1654	2310	2018	2500
G	Track width (Standard/Narrow tyres)	mm	850/782	1360	1360	1850	1850	1880
I	Height to front lip of skip (untipped)	mm	1134/*2259	1367	1467	1672	1719	1732
H	Height to front lip of skip (tipped)	mm	452/*1573	306	856	310	1122	415
J	Load over height	mm	1268/*2392	1504	1567	1791	1764	2001
K	Height over skip (tipped)	mm	1812/*3037	2085	2860	2411	2869	2680
L	Skip tip angle	°	90	75	67	80	70	80
M	Discharge distance front	mm	391	568	548	604	582	526
	Discharge distance side	mm	-	-	319	-	241	-
	Turning radius to outside of skip	mm	5448	5448	4573	5900	6047	6372
	Turning radius to outside of tyres	mm	5430	4464	4464	5755	5739	6218
	Steering angle (+/-)	degrees	39	30	30	30	30	30
	Oscillation	degrees	15	10.5	10.5	10	10	10
N	Height to top of ROPS (with/without beacon)	mm	2792/2573	3016/2835	3016/2835	3354/3131	3354/3131	-
N	Height to top of ROPS/FOPS (with/without beacon)	mm	-	-	-	3354/3169	3354/3169	3570/3385
O	Height with folded ROPS	mm	1721	1857	1857	2013	2169	2319
P	Height with folded ROPS/FOPS	mm	-	-	-	2936	2936	3154
Q	Height to top of cab (with/without beacon)	mm	-	-	-	3296/3014	3296/3014	3295/2994

*With high tip mechanism raised.

CAPACITIES

		1T-1 HT	3T-1 FT	3T-1 ST	6T-1 FT	6T-1 ST	7T-1 Hi-Viz FT	9T-1 FT
Payload	kg	1000	3000	3000	6000	6000	7000	9000
Operating weight - ISO6016 full tank of fuel & 75kg operator (ROPS)	kg	1400	2325	2450	4900	5130	-	5460
Operating weight - ISO6016 full tank of fuel & 75kg operator (ROPS/FOPS)	kg	-	-	-	4980	5210	-	5540
Operating weight - ISO6016 full tank of fuel & 75kg operator (Cab)	-	-	-	-	5240	5470	5620	5800
Tipping type		Front tip - high tip	Front tip	Swivel tip	Front tip	Swivel tip	Front tip	Front tip
Skip capacity (fluid)	l	307	1050	930	1974	1615	2015	2435
Skip capacity (struck)	l	454	1420	1237	2537	2514	3030	3735
Skip capacity (heaped)	l	554	1723	1615	3191	3149	3520	4531

ENGINE								
		1T-1 HT	3T-1 FT	3T-1 ST	6T-1 FT	6T-1 ST	7T-1 Hi-Viz FT	9T-1 FT
Engine model		Kubota D905		Kubota D1703			JCB EcoMAX	
Capacity	cc	898		1647			4400	
Aspiration		Naturally Aspirated		Naturally Aspirated			Turbocharged	
Cylinders		3		3			4	
Max. gross power to SAE J1995/ISO 14396	kW (hp)	15.5 (20.8)		27.4 (36.8)			55 (74)	
Max. torque	Nm	55.8		111.7			400	
Emissions compliance		EU Stage 3A		EU Stage 3A			EU Stage 3B / Tier 4 Final	

TRANSMISSION							
		1-T HT	3T MANUAL	3T HYDROSTATIC	6T	7T	9T
Type		Hydrostatic pump to 4 hydraulic wheel motors	Manual gearbox via transfer box to front and rear axles	Hydrostatic motor via transfer box to front and rear axles		Powershuttle	
Tyre size		255 / 75 x 15.3 x 8 ply (option 7.0 x 12 narrow tyre)	295 / 80 x 15.3 (10 ply)	295 / 80 x 15.3 (10 ply)		405–70–20 14PR	500–60–22.5 16PR
Drive		Hydrostatic 1/1	Manual – 3 Forward / 1 Reverse	2 / 2 (High and low range – forward and reverse) Hydrostatic – permanent 4WD		4 / 4 Forward and reverse – permanent 4WD	
Max. travel speed (unladen) 1st gear	mph (kph)	7.4 (11.9)	2.9 (4.8)	5.0 (8) - Tortoise	3.1 (5.0)	2.8 (4.5)	2.8 (4.5)
Max. travel speed (unladen) 2nd gear	mph (kph)	-	6.8 (11)	13.7 (22) - Hare	5.0 (8.1)	4.7 (7.5)	4.7 (7.5)
Max. travel speed (unladen) 3rd gear	mph (kph)	-	12.4 (20)	-	9.4 (15.2)	8.8 (14.1)	8.8 (14.1)
Max. travel speed (unladen) 4th gear	mph (kph)	-	-	-	15.9 (25.6)	15.3 (24.7)	15.3 (24.7)

ELECTRICAL SYSTEM							
		1-T HT	3T MANUAL	3T HYDROSTATIC	6T	7T	9T
System voltage	V				12		
Alternator output	A	40		60		95	
Battery capacity	Ah	80		80		110	

SERVICE FILL CAPACITIES							
		1-T HT	3T MANUAL	3T HYDROSTATIC	6T	7T	9T
Hydraulic tank	l	28		35		60	
Fuel tank	l	30		35		65	

BRAKING							
		1-T HT		3T		6T-1, 7T-1 & 9T-1	
Working brake		Hydrostatic dynamic braking on rear wheel motors		Multi-plate in-board oil immersed discs on front axle		Foot brake-oil immersed discs on front/rear	
Parking brake		Hydrostatic dynamic braking on rear wheel motors		Over centre handbrake-oil immersed discs on front axle		Over centre parking brake-dry disc on gearbox	

OPTIONS					
	1T-1	3T-1	6T-1	7T-1	9T-1
Folding ROPS frame (site and risk assessment dependent on 6T-1 & 9T-1 models, JCB recommends FOPS fitment)	•	•	+		+
Folding ROPS/FOPS Lvl II frame			•		•
Plastic yellow ROPS/FOPS roof cover			+		+
JCB SiTESAFE Cab (ROPS/FOPS Level II) with heater and protective front screen			+	•	+
JCB SiTESAFE Canopy (ROPS/FOPS Level II) with protective front screen			+	+	+
Front screen guard			+	+	+
Reversing alarm	•	•	•	•	•
White noise reversing alarm	+	+	+	+	+
Dual circuit braking			•	•	•
Speedometer			•	•	•
Tie-down and lifting points	•	•	•	•	•
Lap belt (high-visibility orange, emergency locking retractor)	•	•	•	•	•
Amber rotating beacon	•	•	•	•	•
LED amber beacon	+	+	+	+	+
LED green beacon with lap belt indicator (Note: not linked to engine start)	+	+	+	+	+
Start-inhibit seat switch	•	•			
Sequenced drive inhibit system; drive linked to seat switch and lap belt engagement			•	•	•
Audible alarm on initial machine movement - Horn sounds twice.			•	•	•
Skip raised audible alarm (Body up indicator)			+	+	+
Seat adjustment: fore/aft, operator weight, back angle	•	•	•	•	•
Recovery hitch	•	•	•	•	•
Full width steer column protection	•	•	•	•	•
CESAR Datatag security	■	■	■	■	■
Traction tyres	•	•	•	•	•
Narrow tyres (7.00 x 12)	+				
High visibility safety paint for steps and handrails	+	+	+	+	+
Rear view mirrors	+	+	+	+	+
Front and rear LED work lights		+	+	+	+
Three-speed-only restriction			+	+	+
Object detection system (requires front camera fitment)			+	+	+
Front camera (compliant with ISO 5006:2017)			•	+	•
Side/Rear Cameras (requires front camera fitment)			+	+	+
Road lights	+	+	+	+	+
LiveLink telematics	+	+	+	+	+
Flexible steps			+	+	+
Rental ready decals - clear skip sides	+	+	+	+	+

- Standard
- + Option
- UK only
Cab only option